

STUDIES OF MOISTURE TRANSPORT PROCESSES IN COMPRESSED POROUS BODIES

L. S. Amaryan, E. T. Bazin, and N. V. Churaev

Inzhenerno-Fizicheskii Zhurnal, Vol. 8, No. 5, pp. 639-643, 1965

Describes a radioisotope tracer method and the corresponding apparatus, and reports the results of determinations of the characteristic pore structure and hydraulic properties of capillary-porous bodies under compression. Studies the mechanism of removal of water from porous materials (peat) compressed at different pressures.

Many technical processes involve the compression of moist materials with the object of expelling water from them. However, moisture transport processes and the changes in the pore structure of compressed materials have still not been sufficiently studied; hence the absence of suitable apparatus and methods of investigation.

In our experiments radioisotope tracer methods were employed [1, 2]. The investigations were carried out on a specially constructed compression filtration apparatus suitable for work with radioisotope tracers (Fig. 1). A sample 71.4 or 112.9 mm in diameter and 30-40 mm high (before compression) was placed in a cup between two filters and compressed by means of a clamping nut, through a spring and piston mechanism. Deformation of the sample was measured by a dial indicator coupled with the piston. The force compressing the spring was determined from the difference between the readings of the dial indicator and a vernier similar to those used in slide gages. If the characteristics of the spring are known, the compressive force and pressure can be calculated from its deformation.

All the components exposed to moisture (cup, filters, cover, and bottom) were made of plexiglas in order to avoid adsorption of radioactive tracer.

Filtration through the apparatus was from bottom to top at pressure gradients  $I = 10-35$ . At first, the sample was slowly saturated with water from below to displace air trapped in the pores. After this, water was allowed to filter through the sample until its structure was stabilized. The necessary pressure gradient was produced by mounting a funnel at a certain height and connecting it to the bottom of the apparatus by a rubber hose. The water level in the funnel was maintained constant by a regulating flask. The filtrate that collected on top of the upper filter was drawn off periodically with a micropipet. After the rate of filtration became constant, the permeability of the initial undeformed specimen was measured, after which the structural characteristics were measured by the radioisotope tracer method. In order to do this, we quickly poured off all the pure water in the lower part of the apparatus, hose and funnel and replaced it with a solution containing  $\text{Na}_2\text{SO}_4$  labeled with a radioisotope  $\text{S}^{35}$  tracer. The specific activity of

this solution was 5-10  $\mu\text{C}/\text{l}$ . To remove air from the lower part of the apparatus (on changing the water) a small glass tube communicating with the atmosphere was mounted under the lower filter; after expulsion of the air this was closed by a stopcock.

Following filtration of the labeled water at the same pressure gradient as before, radiometric analysis was performed on samples of the filtrate collected with the micropipet. The results were processed by the method described in

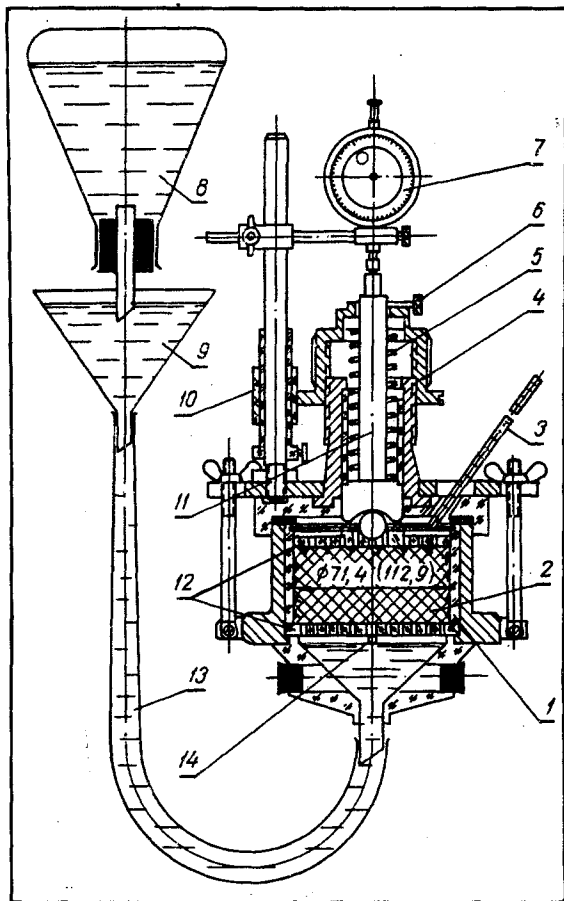

Fig. 1. Compression-filtration apparatus for work with radioisotope tracers: 1) cup; 2) sample; 3) micropipet; 4) clamping nut; 5) spring; 6) set screw; 7) dial indicator; 8) regulating flask; 9) funnel; 10) vernier; 11) piston; 12) filters; 13) rubber hose; 14) glass tube communicating with atmosphere.

[2]. Then the process was reversed by displacing the labeled water from the pores of the sample with pure water, to check the results of the direct experiment.

When all the measurements on the undeformed sample had been completed, the first pressure level was established by the mechanism already described. The end of compaction of the sample and its new thickness were determined from the readings of the dial indicator. The piston was then locked by the set screw.

Then the permeability of the compressed sample was measured, and its structural characteristics were determined by means of the radioisotope tracer. In this way, by means of a series of constant pressure increases in the apparatus, it was possible to follow the variation in hydraulic properties and structure during compression.

In these experiments we investigated a medium peat with a low degree of decomposition ( $R = 10\%$ ); this is known to be an easily deformable capillary-porous body with a high intracellular and capillary water content [3]. It is used, for example, in the production of pressed peat bedding and insulating tiles [4, 5].

For sampling the peat, a rotary cutter sampler [6] was used. The drive used under field conditions was a power saw gasoline engine. By regulating the cutter speed we obtained a cylindrical sample with a practically undisturbed structure; this was extremely difficult to achieve with an ordinary cutting cylinder.

The surface of the sample resting against the lateral face of the cup in the test apparatus was smeared with grease or well-dispersed moist peat to prevent leakage along the boundary. In addition, the cup was heated to  $313-323^\circ\text{K}$ . On cooling, it tightly gripped the surface of the sample.

The results of one experiment on a sample of medium peat ( $R = 10\%$ ) are presented in Fig. 2, which shows that the equivalent diameter of the pores  $D$  decreases from  $2.5-20 \mu\text{m}$  in the original undeformed peat to  $0.2-2 \mu\text{m}$  in peat compressed at  $3.1 \cdot 10^4 \text{ n/m}^2$ . In addition, the peat pores become significantly more uniform in size under compression. Most significant is the change in maximum pore diameter, which is related to the elimination by compression of the largest voids. In spite of the obvious presence in the system of micropores ( $r = D/2 < 0.1 \mu\text{m}$ ), they do not take part in moisture transport even at the maximum applied pressure gradient ( $l = 35$ ) in the experiment at  $p = 3.1 \cdot 10^4 \text{ n/m}^2$ .

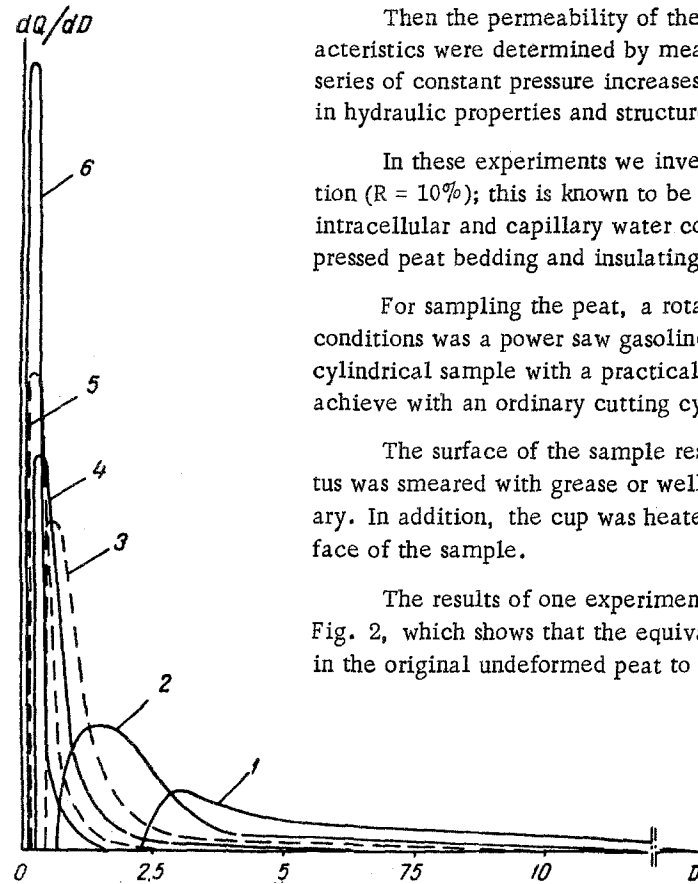

Fig. 2. Distribution curve of filtration flow  $Q$  according to pore size  $D$  for different amounts of compression. 1) Initial undeformed sample; 2-6) pressure equal respectively to  $(0.82; 1.53; 2.04; 2.65; 3.1) \cdot 10^4 \text{ n/m}^2$ .

radius of the pores and an increase in the kinetic specific surface from  $0.3$  to  $5.7 \text{ m}^2/\text{g}$ . Notwithstanding the decrease in porosity  $n = (V - V_T)/V$  due to removal of water from the peat, its active porosity  $m = (V - V_T - V_N)/V$  increases. This is connected with the removal primarily of the weakly bound intracellular (immobile) water that occupies cavities in the undecomposed plant fragments [1, 7]. Another cause of the increase in  $m$  is the elimination of large pore channels (Fig. 2), as a result of which the difference in size of the pores between particles and the pores penetrating the peat particles (fibers) is reduced. Therefore in the compressed peat, filtration takes place not only through the original pores but also through the fibrous particles, which increases the relative volume of mobile water. Thus, the conversion of intracellular water (immobile in the original peat) into free water may take place not only as a result of its expulsion from the fibers but also as a result of its entrainment in the filtration flow in connection with the equalization of the structure of the sample.

The decrease in permeability  $K_f$  in compressed peat might be still more significant if compression were not accompanied by an increase in active porosity. Curve 2 in Fig. 3 illustrates how the permeability of peat  $K_f^*$  would decrease if the immobile water content remained constant during compression.

As seen from Fig. 3, for example, the value  $K_f^* = 0.00343 \text{ cm/hr}$  would be recorded at a pressure  $p = 0.4 \cdot 10^4 \text{ n/m}^2$ , whereas the measured value  $K_f = 0.00343 \text{ cm/hr}$  corresponds to a pressure  $p = 3.1 \cdot 10^4 \text{ n/m}^2$ .

The variation in the moisture content of the peat during compression is shown in Fig. 4. The difference between the ordinates of curve 1 and curve 2 in this figure corresponds to the free water content occupying the pores at different pressures. Analysis of the graphs shows that in the first stage of compression the more weakly bound intracellular is pre-

ferentially removed; this process is complete at  $p \approx 5 \cdot 10^4 \text{ n/m}^2$ . At pressures  $p = 1 \cdot 10^4 - 2 \cdot 10^4 \text{ n/m}^2$  together with continuing expulsion of intracellular water, removal of water from the free pores also begins. At pressures greater than  $5 \cdot 10^4 \text{ n/m}^2$  loss of moisture depends on the removal of free water from micropores, and the rate of dewatering decreases. In this case, the only immobile water is that which is physico-chemically bound; at low pressures the content of this water does not decrease, as shown in Fig. 4.

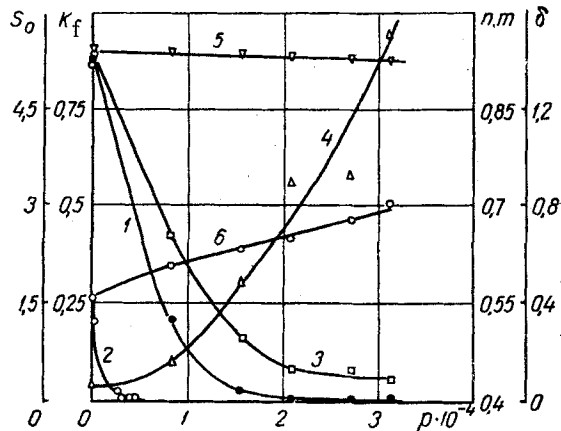

Fig. 3. Change in permeability coefficients  $K_f$ , cm/hr (1), and  $K_f^*$  (2), hydraulic radius of pores  $\delta$ ,  $\mu\text{m}$  (3), kinetic specific surface  $S_0$ ,  $\text{m}^2/\text{g}$  (4), porosity  $n$  (5), and active porosity  $m$  (6) during compression of peat.

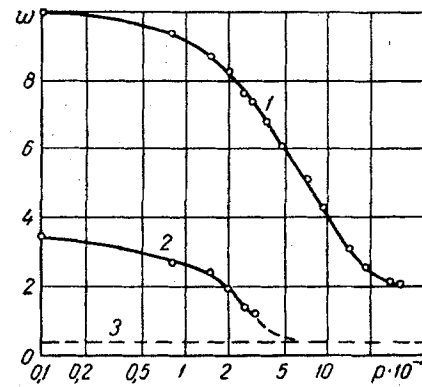

Fig. 4. Change in moisture content of peat (1), intracellular water content (2), and physico-chemically bound (immobile) water content (3).

The data obtained on the mechanism of moisture transport during compression of peat, which confirm and extend the findings of earlier investigations [1, 3, 7], can be used to develop optimal techniques for the mechanical drying of peat with a low degree of decomposition. Our radioisotope tracer method and compression-filtration apparatus are suitable for studying the mechanism of compaction of other colloidal capillary-porous materials.

#### NOTATION

$S_0$  – kinetic specific surface;  $\delta = m/S_0$  – mean hydraulic pore radius;  $I$  – pressure gradient;  $R$  – degree of decomposition of peat;  $D$  – equivalent diameter;  $p$  – pressure;  $K_f$  – permeability;  $V$  – volume of specimen;  $V_T$  – volume of solid phase;  $V_N$  – volume of fixed water.

#### REFERENCES

1. M. P. Volarovich and N. V. Churaev, Studies of Peat Using Radioactive Isotopes [in Russian], Izd. AN SSSR, 1960.
2. N. V. Churaev, collection: New Physical Methods for the Investigation of Peat [in Russian], Gosenergoizdat, 1960.
3. N. V. Churaev, Doctoral Dissertation, Kalinin Peat Institute, 1961.
4. V. Ya. Antonov et al., General Course in Peat Technology [in Russian], Gosenergoizdat, 1959.
5. M. A. Sukhanov, Thermal-Insulation Materials from Peat [in Russian], Gosenergoizdat, 1960.
6. A. A. Tkachenko, Osnovaniya, fundamenty i Mekhanika gruntov, no. 6, 1961.
7. N. V. Churaev, Torfyanaya promyshlennost, no. 1, 1963.

16 June 1964

Kalinin Peat Institute